

NEW

MSD  TM

**FAST DEPLOYMENT, HIGH THROUGHPUT, FERROUS
MASS CASUALTY METAL THREATS DETECTION SYSTEM
FOR SCREENING OF PEOPLE IN STREET CLOTHES**



www.ceia.net

CEIA reserves the right to make changes, at any moment and without notice, to the models (including programming), their accessories and options, to the prices and conditions of sale. DP220K0002v1.000hEN



CEIA introduces **MSD EVO™**, the **latest CEIA Ferromagnetic Detector (FMD)**, with outstanding capabilities in security pass-through applications defined by multiple ferromagnetic poles.

The compact **MSD EVO™** unit targets ferrous assault weapons capable of mass destruction including large firearms and pipe bombs and provides fast throughput screening of individuals in street clothes attending public events such as sporting events, concerts, theaters, galas, etc.

Inside the transit area, the **MSD EVO™** improves detection uniformity 100 times over conventional ferromagnetic (FMD) pole pairs, offers better discrimination against ferromagnetic personal items and greater immunity against external interference sources (i.e. moving metals or electrical interferences).

Multiple side-by-side entrances are quickly and readily deployed by a sequence of **MSD EVO™** units where each unit separately combines with the two adjacent poles that provide two independent gates with the same detection and discrimination capability of the single pair.



MSD EVO™ HIGHLIGHTS

- **DETECTION TARGET:** ferrous weapons of mass destruction
- **OPERATIONAL USE:** fast throughput screening of people in street clothes
- **APPLICATION FIELDS:** sporting events, concerts, theaters, galas, etc.
- Simultaneous optical alarm signaling provided by the two poles defining the alarmed transit zone
- Optional installation of up to 10 barriers of 100 **MSD EVO™** each (99 gates) with automatic synchronization of the adjacent units
- Programmable sensitivity of a series of multiple **MSD EVO™** poles by a single operation on the first **MSD EVO™** pole of the line, without the need for individual pole adjustments
- No assembly required: 10 second set-up
- Battery life: 26 hours, continuous operation
- Ready for immediate shipping
- Further data and practical demos available upon request

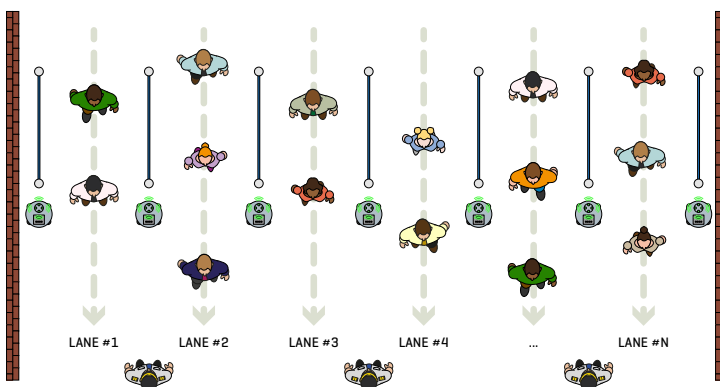

Example of multiple gates with MSD EVO series

DIMENSIONS

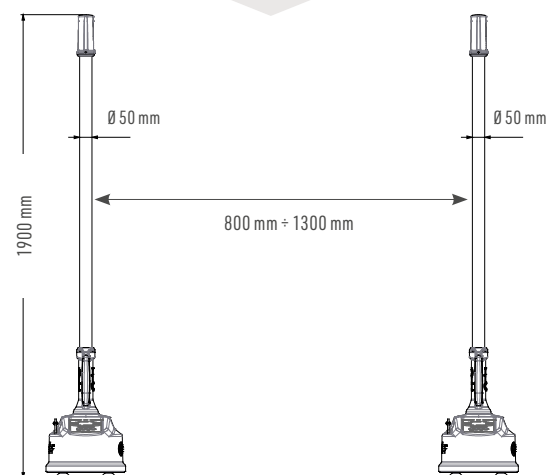

AVAILABLE ACCESSORIES

Bluetooth audio function activation, headset and charger: ordering code 88919

Solid Rubber feet and tools for uneven floor: ordering code 88917



CEIA - Zona Industriale 54, 52041 Vicinaggio - Arezzo (ITALY)
T +39 0575 4181 • F +39 0575 418298 • E infosecurity@ceia-spa.com

www.ceia.net

